

TECHNICAL MANUAL
CALIBRATION PROCEDURE
FOR
SYNTHESIZED SIGNAL GENERATOR
8642A (), 8642B ()

(HEWLETT-PACKARD)

This publication replaces T.O. 33K4-4-260-1 dated 30 May 2003 and all subsequent changes.

Distribution Statement C - Distribution authorized to U. S. Government agencies and their contractors for official use or for administrative or operational purposes only, 30 April 1988. Requests for this document shall be referred to AFMETCAL, 813 Irving-Wick Dr W, Heath, OH 43056-1199.

Destruction Notice - For unclassified, limited documents, destroy by any method that will prevent disclosure of the contents or reconstruction of the document.

T.O. 33K4-4-260-1

LIST OF EFFECTIVE PAGES

INSERT LATEST CHANGED PAGES. DESTROY SUPERSEDED PAGES.

NOTE: The portion of the text and illustrations affected by the changes is indicated by a vertical line in the outer margins of the page.

Date of issue for original and changed pages are:

Original.....0 30 September 2010

TOTAL NUMBER OF PAGES IN THIS PUBLICATION IS 46, CONSISTING OF THE FOLLOWING:

Page No.	* Change No.	Page No.	* Change No.	Page No.	* Change No.
Title	0				
A	0				
1 - 40.....	0				
A-1	0				
A-2 Blank	0				
B-1	0				
B-2 Blank.....	0				

*Zero in this column indicates an original page

SYNTHESIZED SIGNAL GENERATOR

8642A (), 8642B ()

(HEWLETT-PACKARD)

1 CALIBRATION DESCRIPTION:*Table 1.*

Test Instrument (TI) Characteristics	Performance Specifications	Test Method
Frequency Accuracy Reference Oscillator	Range: 10 MHz Accuracy: (STD) Accuracy: $\pm 2 \times 10^{-6}$ * ¹ Aging/year: $< 2 \times 10^{-6}$ (Not adjusted) Temperature: $< 4 \times 10^{-6}$ (0 to 55 °C) * ² Line Voltage: $< 1 \times 10^{-7}$ * ² , * ³ Accuracy: (OPT 001) Accuracy: $\pm 3.6 \times 10^{-7}$ * ¹ Aging/day: $< 1 \times 10^{-9}$ Temperature: $< 7 \times 10^{-9}$ (0 to 55 °C) * ² Line Voltage: $< 3 \times 10^{-9}$ * ² , * ³	Compared to a Frequency Standard
Display 8642A	Range: 100 kHz to 1057.5 MHz Accuracy: ± 1 count of LSD	Compared to a Frequency Counter
8642B	Range: 100 kHz to 2115 MHz Accuracy: ± 1 count of LSD	
RF Output Power 8642A	Range: -140 to +20 dBm, Bands 1 through 7; -140 to +18 dBm, Band 8, HET Band; -140 to +16 dBm, Band 9	Measured with a Sensor Module and Microwave Measurement System
8642B	Range: -140 to +20 dBm, Bands, 1 through 7; -140 to +19 dBm, Band 8; -140 to +18 dBm, HET Band; -140 to +17 dBm, Band 9; -140 to +16 dBm, Band 10	

See footnotes at end of Table.

Table 1. (Cont.)

Test Instrument (TI) Characteristics	Performance Specifications	Test Method
RF Output Power (<i>Cont.</i>) Absolute Level	Range: ≥ -127 dBm Output Accuracy: ± 1 dB	Measured with a Sensor Module and Microwave Measurement System
Flatness	Range: $+10$ dBm Output Level Accuracy: $< \pm 0.75$ dB	
Spurious Signals Harmonics	Range: Bands 1 through 9, HET Accuracy: ≤ -30 dBc @ $\leq +10$ dBm; ≤ -20 dBc @ $\leq +16$ dBm Range: Band 10 (8642B only) Accuracy: ≤ -25 dBc @ $\leq +10$ dBm; ≤ -20 dBc @ $\leq +16$ dBm	Measured with a Spectrum Analyzer
Subharmonics	Range: Bands 1 through 9, HET Accuracy: None * ⁴ Range: Band 10, (8642B only) Accuracy: ≤ -45 dBc	
Non-Harmonics	Range: Bands 1 through 9 @ > 10 kHz from the carrier Accuracy: ≤ -100 dBc Range: Band 10 (8642B only) @ > 10 kHz from the carrier Accuracy: ≤ -94 dBc	Measured with a Phase Noise Measurement System

See footnotes at end of Table.

Table 1. (Cont.)

Test Instrument (TI) Characteristics	Performance Specifications	Test Method
SSB Phase Noise (CW, AM, or Angle Modulation <1/60 maximum peak deviation)	Range: 20 kHz offset from carrier Accuracy: *5 Band 10: (8642B only) 1057.500001 to 2115 MHz, ≤-125 dBc/Hz; Band 9: 528.750001 to 1057.5 MHz, ≤-134 dBc/Hz; Band 8: 264.375001 to 528.75 MHz, ≤-137 dBc/Hz; Band 7: 132.187501 to 264.375 MHz, ≤-141 dBc/Hz; Band 6: 66.093751 to 132.1875 MHz, ≤-144 dBc/Hz; Band 5: 33.046876 to 66.09375 MHz, ≤-145 dBc/Hz; Band 4: 16.523438 to 33.046875 MHz ≤-146 dBc/Hz; Band 3: 8.261719 to 16.523437 MHz, ≤-147 dBc/Hz; Band 2: 4.13086 to 8.261718 MHz, ≤-148 dBc/Hz; Band 1: 0.1 to 4.130859 MHz, ≤-137 dBc/Hz; HET: 0.1 to 132.1875 MHz, ≤-125 dBc/Hz	Measured with a Phase Noise Measurement System
Residual FM	Range: 0.3 to 3 kHz BW Band 10, <5.0 Hz rms (8642B only); Band 9, <2.0 Hz rms; Band 8, <1.2 Hz rms; Bands 1 to 7, <1.0 Hz rms; Band HET, <3.5 Hz rms Range: 0.05 to 15 kHz BW Accuracy: Band 10, <9.0 Hz rms (8642B only); Band 9, <5.0 Hz rms; Band 8, <2.0 Hz rms; Bands 1 to 7, <1.2 Hz rms; Band HET, <5.0 Hz rms	

See footnotes at end of Table.

Table 1. (Cont.)

Test Instrument (TI) Characteristics	Performance Specifications	Test Method
SSB Phase Noise Floor	Range: 200 kHz offset from carrier Accuracy: Band 10: (8642B only) 1057.500001 to 2115 MHz, ≤ -134 dBc/Hz; Band 9: 528.750001 to 1057.5 MHz, ≤ -143 dBc/Hz; Band 8: 264.375001 to 528.75 MHz, ≤ -144 dBc/Hz; Band 7: 132.187501 to 264.375 MHz, ≤ -144 dBc/Hz; Band 6: 66.093751 to 132.1875 MHz, ≤ -145 dBc/Hz; Band 5: 33.046876 to 66.09375 MHz, ≤ -145 dBc/Hz; Accuracy: Band 4: 16.523438 to 33.046875 MHz, ≤ -147 dBc/Hz; Band 3: 8.261719 to 16.523437 MHz, ≤ -148 dBc/Hz; Band 2: 4.13086 to 8.261718 MHz, ≤ -149 dBc/Hz; Band 1: 0.1 to 4.130859 MHz, ≤ -138 dBc/Hz; HET: 0.1 to 132.1875 MHz, ≤ -137 dBc/Hz	Not Calibrated
Amplitude Modulation	Range: 0 to 99.9% depth Accuracy: See Indicator Accuracy	Measured with a Microwave Measurement System
Indicator Accuracy 8642A	Range: Bands 1 through 8, HET	
8642B	Range: Bands 1 through 9, HET	
	Accuracy: $\pm(3.5\%$ of setting + 1% AM) @ 1 kHz rate, up to 90% AM	
8642A	Range: Band 9	
8642B	Range: Band 10	
	Accuracy: $\pm(5\%$ of setting + 1% AM) @ 1 kHz rate, up to 90% AM	
Incidental \emptyset M	Range: 1 kHz rate and 30% AM Accuracy: <0.2 radians peak	

Table 1. (Cont.)

Test Instrument (TI) Characteristics	Performance Specifications	Test Method
Amplitude Modulation (<i>Cont.</i>) AM Distortion 8642A	Range: Bands 1 through 8 Accuracy: <1% @ 0 to 30% AM; <2% @ 30 to 70% AM; <4% @ 70 to 90% AM Range: Band 9, HET Accuracy: <2% @ 0 to 30% AM; <4% @ 30 to 70% AM; <6% @ 70 to 90% AM	Measured with a Microwave Measurement System
8642B	Range: Bands 1 through 9 Accuracy: <1% @ 0 to 30% AM; <2% @ 30 to 70% AM; <4% @ 70 to 90% AM Range: Band 10, HET Accuracy: <2% @ 0 to 30% AM; <4% @ 30 to 70% AM; <6% @ 70 to 90% AM	
Phase Modulation Maximum Phase Deviation	Range: Band 10: 200 radians (8642B only); Band 9: 100 radians; Band 8: 50 radians; Band 7: 25 radians; Band 6: 12.5 radians; Band 5: 6.25 radians; Band 4: 3.125 radians; Band 3: 1.5625 radians; Band 2: 0.78125 radians; Band 1: 6.25 radians; HET: 100 radians Accuracy: ±(5% of setting + 0.09 radians) @ 1 kHz rate	
Ø M Distortion	Range: 1 kHz rate Accuracy: <0.4% @ 1 kHz rate	

Table 1. (Cont.)

Test Instrument (TI) Characteristics	Performance Specifications	Test Method
Frequency Modulation Maximum Peak Deviation	Range: N/A Accuracy: Band 10: 3 MHz (8642B only); Band 9 and HET: 1.5 MHz; Band 8: 750 kHz; Band 7: 375 kHz; Band 6: 187.5 kHz; Bands 5 and 1: 93.75 kHz; Band 4: 46.875 kHz; Band 3: 23.437 kHz; Band 2: 11.718 kHz	Measured with a Microwave Measurement System
Indicator Accuracy	Range: 20 Hz to 100 kHz rates Accuracy: $\pm(5\%$ of setting + 10 Hz)	
Incidental AM	Range: 20 kHz peak deviation, 1 kHz rate, >400 kHz carrier frequency, Output Level $\leq +15$ dBm Accuracy: <0.3%	
FM Distortion	Range: 20 Hz to 100 kHz rates Accuracy: <4% for max dc-coupled deviation; <2% for 1/2 max dc-coupled deviation; <0.4% for 1/15 dc-coupled deviation	
Pulse Modulation ON/OFF Ratio	Range: Bands 1 through 9, HET, Output Level $\leq +15$ dBm Accuracy: >30 dB (S/N 2509A to 2550A); >40 dB (S/N $\geq 2551A$) Range: Band 10, Output Level $\leq +15$ dBm (P/N 8642B only) Accuracy: >45 dB (S/N 2509A to 2550A); >80 dB (S/N $\geq 2551A$)	

Table 1. (Cont.)

Test Instrument (TI) Characteristics	Performance Specifications	Test Method
Rise/Fall Time	Range: Bands 1 through 10, HET, @ 10 to 90% Accuracy: <3.5 μ s (S/N 2509A to 2550A); <400 ns (S/N \geq 2551A)	Measured with a Oscilloscope
Residual AM	Range: 0.3 to 3 kHz BW Accuracy: <0.01% AM rms	Measured with a Microwave Measurement System
Internal Modulation Oscillator Frequency	Range: 20 Hz to 100 kHz Accuracy: 2% of setting	Measured with an Audio Analyzer
Output Level	Range: 0 to 3.3 V _p Accuracy: $\pm(4\% + 15 \text{ mV})$	
Distortion	Range: 0.02 to 15.8 kHz Accuracy: <0.02% Range: >15.8 kHz Accuracy: <0.15%	

*¹ The accuracy is the manufacturers calculated specification after one year. The accuracy specification is found by multiplying the longest term aging rate by the appropriate time interval to obtain one year.

*² Typical or Operational specifications. Not calibrated.

*³ For a +5% to -10% change in line voltage.

*⁴ By design, Subharmonics are not produced and therefore not checked.

*⁵ See step 3.4.

2 EQUIPMENT REQUIREMENTS:

Noun	Minimum Use Specifications	Calibration Equipment	Sub-Item
2.1 FREQUENCY STANDARD	Range: 10 MHz Accuracy: $\leq 2.5 \times 10^{-10}$	Arbiter 1083B	
2.2 ELECTRONIC COUNTER	Range: 10 MHz Accuracy: ± 1 count of LSD	Hewlett-Packard 5345A W/ Opt 001	
2.3 FREQUENCY COUNTER	Range: 4 to 2115 MHz Accuracy: ± 1 count of LSD	Hewlett-Packard 5343A	
2.4 FREQUENCY DIFFERENCE METER	Range: 1×10^{-7} to 1×10^{-11} Accuracy: N/A	Tracor 527E	
2.5 OSCILLOSCOPE	Range: (Bandwidth) 3.5 MHz Accuracy: ≤ 100 ns	Tektronix 2465B	
2.6 MICROWAVE MEASUREMENT SYSTEM	Range: (RF Power) -1 to +21 dBm Accuracy: $\pm 2\%$ of indication Range: (Tuned RF Level) 0 to -127 dB Accuracy: ± 0.25 dB Range: (AM) 30 to 90% Accuracy: $\pm 1.11\%$ of setting Range: (FM) ≤ 400 kHz peak deviation Accuracy: $\pm 1.25\%$	Hewlett-Packard 8902MS	

Noun	Minimum Use Specifications	Calibration Equipment	Sub-Item
2.6 MICROWAVE MEASUREMENT SYSTEM (<i>Cont.</i>)	<p>Audio Filters: 50 Hz High-Pass Filter, <1% at rates ≥ 200 Hz; 300 Hz High-Pass Filter, <1% at rates ≥ 1 kHz; 3 kHz Low-Pass Filter, <1% at rates ≤ 1 kHz; 15 kHz Low-Pass Filter, <1% at rates ≤ 10 kHz; >20 kHz Low-Pass Filter, <1% at rates ≤ 10 kHz</p> <p>Range: (Phase Modulation)</p> <p>Accuracy: $\pm(2.75\%$ of reading + 1 digit)</p> <p>TAR: 1.8:1</p>	Hewlett-Packard 8902MS	
2.7 AUDIO ANALYZER	<p>Range: 20 Hz to 100 kHz</p> <p>Accuracy: (Frequency) 0.5% of rdg</p> <p>Accuracy: (Distortion) The higher of 0.01% (-80 dB) or 30 mV, 20 Hz to 20 kHz, 80 kHz BW; The higher of 0.032% (-70 dB) or 95 mV, 20 to 50 kHz, 500 kHz BW; The higher of 0.056% (-65 dB) or 169 mV, 50 to 100 kHz, 500 kHz BW</p> <p>Accuracy: (AC Level): $\pm 2\%$ of rdg, 50 mV to 300 V, 20 Hz to 20 kHz; $\pm 4\%$ of rdg, 50 mV to 300 V, 20 to 100 kHz</p>	Hewlett-Packard 8903B	

Noun	Minimum Use Specifications	Calibration Equipment	Sub-Item
2.8 SENSOR MODULE (P/O MICROWAVE MEASUREMENT SYSTEM)	Range: -1 to +21 dBm ±3.2%, of Charted Cal Factor 100 kHz; ±2.5%, of Charted Cal Factor 200 kHz to 10 MHz; ±3.2%, of Charted Cal Factor 10 to 100 MHz; ±2.6%, of Charted Cal Factor 100 MHz to 2.6 GHz	Hewlett-Packard 11722A	
2.9 SPECTRUM ANALYZER	Range: 3 to 6000 MHz Accuracy: (Scale Fidelity) ±1.6 dB	Hewlett-Packard 8563E	
2.10 PHASE NOISE MEASUREMENT SYSTEM	Range: 4.0 MHz to 2.0 GHz Accuracy: (Phase Noise) Offsets (10 Hz to 100 kHz), ±2 dB; (Residual FM) ±2 dB TAR: (worst case, Residual FM) 3.9:1	Hewlett-Packard E5504B	
2.11 SYNTHESIZED FUNCTION GENERATOR	Range: 50 or 100 kHz; (Pulse Width) 2 to 6 µs; Amplitude, 0 to 1 V Accuracy: Rise/Fall Time ≤100 ns	Hewlett-Packard 8114A	
2.12 DETECTOR	Range: 100 to 1300 MHz Accuracy: N/A	Hewlett-Packard 423B	
2.13 BNC-T ADAPTER	Range: N/A Accuracy: N/A	As Available	
2.14 FEEDTHROUGH TERMINATION	Range: 50 Ω Accuracy: N/A	As Available	
2.15 ATTENUATOR	Range: 20 dB, 0.15 to 2000 MHz Accuracy: N/A	Hewlett-Packard 8491B OPT020	
2.16 HIGH PASS FILTER	Range: 150 MHz Accuracy: N/A	Mini Circuits NHP-150	

3 PRELIMINARY OPERATIONS:

3.1 Review and become familiar with entire procedure before beginning Calibration Process.



Unless otherwise designated, and prior to beginning the Calibration Process, ensure that all test equipment voltage and /or current outputs are set to zero (0) or turned off, where applicable. Ensure that all equipment switches are set to the proper position before making connections or applying power. If not strictly observed, could result in injury to, or death of, personnel or long term health hazards.

3.2 Connect the TI to appropriate power source, and ensure that the POWER switch is ON.

NOTE

The TI must have a 24 hour warm-up if it has been disconnected from the power source for less than 24 hours. If TI has been disconnected from the power source for 24 hours or more, the TI technically should be warmed up for 8 days. This may not be practical. Experience has shown that about 85% of new units and 95% of older units will be within specifications after a 24 hour warm-up. If TI fails the Frequency Accuracy and Display Calibration, the TI may be checked at 24 hour intervals up to the manufacturers stated warm-up time. If the TI passes the Frequency Accuracy and Display Calibration at any of these intermediate warm-up times, commence with the calibration. If the TI fails all intermediate intervals and after the manufacturers stated warm-up time, then perform the applicable maintenance actions for failure.

3.3 Connect test equipment to the appropriate power source, set all POWER switches to ON and allow warm-up period as required by manufacturer of test equipment.

3.4 The TI must be limited due to the accuracy of the Phase Noise Measurement System. This is the accuracy that must be applied to the TI. See Appendix B, Table B-1.

3.4.1 Annotate and attach a Limited Certification Label listing the applicable limitations listed in the TI Limitations column of Appendix B, Table B-1 and stating SSB Phase Noise Floor (@ 200 kHz offset) not calibrated.

4 CALIBRATION PROCESS:**NOTE**

Unless otherwise specified, verify the results of each test and take corrective action whenever the test requirement is not met, before proceeding.

4.1 FREQUENCY ACCURACY AND DISPLAY CALIBRATION:**NOTE**

Adjustment of the Time Base Oscillator is normal due to the aging rate of the crystal. This is common to all Quartz Oscillators. The adjustment actions taken during this calibration will ensure the greatest reliability of the TI by adjusting the time base reference to the nominal value each time it is calibrated.

4.1.1 For STD TI proceed to step 4.1.3. Connect Frequency Standard 10 MHz REF OUT to Electronic Counter EXT FREQ STD INPUT (1-10 MHz) (rear panel). Connect TI 10 MHz OUT (rear panel) to Electronic Counter CHANNEL A input connector. Set Electronic Counter INT STD/EXT STD switch to EXT STD.

NOTE

The values in the following step are derived from multiplication of the Aging Rate to determine the offset at one year. Use these calculated one year values regardless of the length of the calibration interval for this TI in T.O. 33K-1-100-1/2.

4.1.2 Adjust Electronic Counter controls as required for a stable display indication and then push RESET. Verify Electronic Counter indication is 9 999 996.4 to 10 000 003.6 Hz. Disconnect the test setup.

4.1.3 Connect equipment as shown in Figure 1. Remove TI FREQ STANDARD jumper so that the connection can be made to the EXT REF INPUT connector.

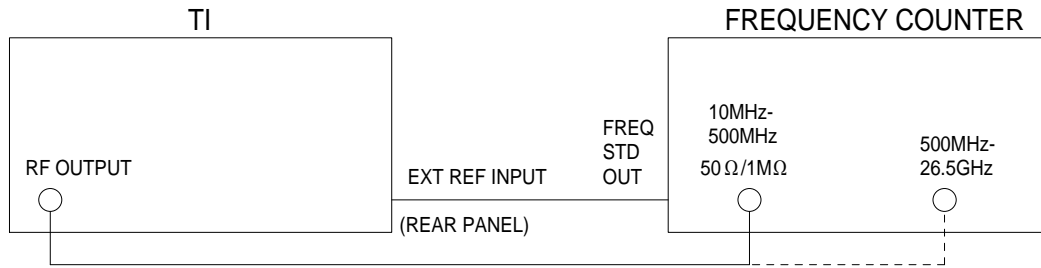

Figure 1.

4.1.4 Set Frequency Counter for 1 Hz display resolution.

4.1.5 Set TI FREQ to the first value listed in the Frequency column of Table 2, AMPTD to 0 dBm, and the RF OFF/ON to ON.

4.1.6 Verify the Frequency Counter indicates within the values listed in the Limits column of Table 2.

4.1.7 Repeat step 4.1.5 and 4.1.6 for the remaining frequencies listed in the Frequency column of Table 2.

Table 2.

Frequency (Hz)	Limits (Hz)
111 111 111	111 111 110 to 111 111 112
222 222 222	222 222 221 to 222 222 223
333 333 333	333 333 332 to 333 333 334
444 444 444	444 444 443 to 444 444 445

Table 2. (Cont.)

Frequency (Hz)	Limits (Hz)
555 555 555 *	555 555 554 to 555 555 556
666 666 666	666 666 665 to 666 666 667
777 777 777	777 777 776 to 777 777 778
888 888 888	888 888 887 to 888 888 889
999 999 999	999 999 998 to 1000 000 000
1000 000 000	999 999 999 to 1000 000 001
2114 000 000 **	2113 999 999 to 2114 000 001

* Connect TI RF OUTPUT to Frequency Counter 500MHz - 26.5GHz Input, as per dotted line in Figure 1.

** For TI P/N 8642B only.

4.1.8 Set TI RF OFF/ON to OFF and disconnect the test setup.

4.1.9 To ensure reliability of the TI, the following action will be taken: If TI passed the above steps, perform the applicable adjustment steps in Appendix A and enter the applicable code into the Maintenance Data Collection System. If TI failed, perform the applicable steps listed in Appendix A and enter the applicable code into the Maintenance Data Collection System.

4.2 RF OUTPUT POWER CALIBRATION:

4.2.1 Standardize the Measuring Receiver (p/o Microwave Measurement System) and Sensor Module. Ensure the Sensor Module calibration data is loaded in the Measuring Receiver.

4.2.2 Press the Measuring Receiver INSTR PRESET. Set the Measuring Receiver for a power measurement.

4.2.3 Connect equipment as shown in Figure 2.

4.2.4 Press TI INSTR PRESET and set AMPTD to +10.0 dBm.

4.2.5 Set TI FREQ to 0.1 MHz.

4.2.6 Press the Measuring Receiver RATIO key, then press LOG/LIN for a dB measurement.

4.2.7 Press TI FREQ key and using the Edit Rotary Knob, vary the frequency from 100 kHz to 1057 MHz (100 kHz to 2115 MHz for TI P/N 8642B). Record the Measuring Receiver minimum and maximum indications.

4.2.8 Determine the difference between the maximum and minimum values recorded in step 4.2.7.

4.2.9 Verify the result of step 4.2.8 is ≤ 1.5 dB.

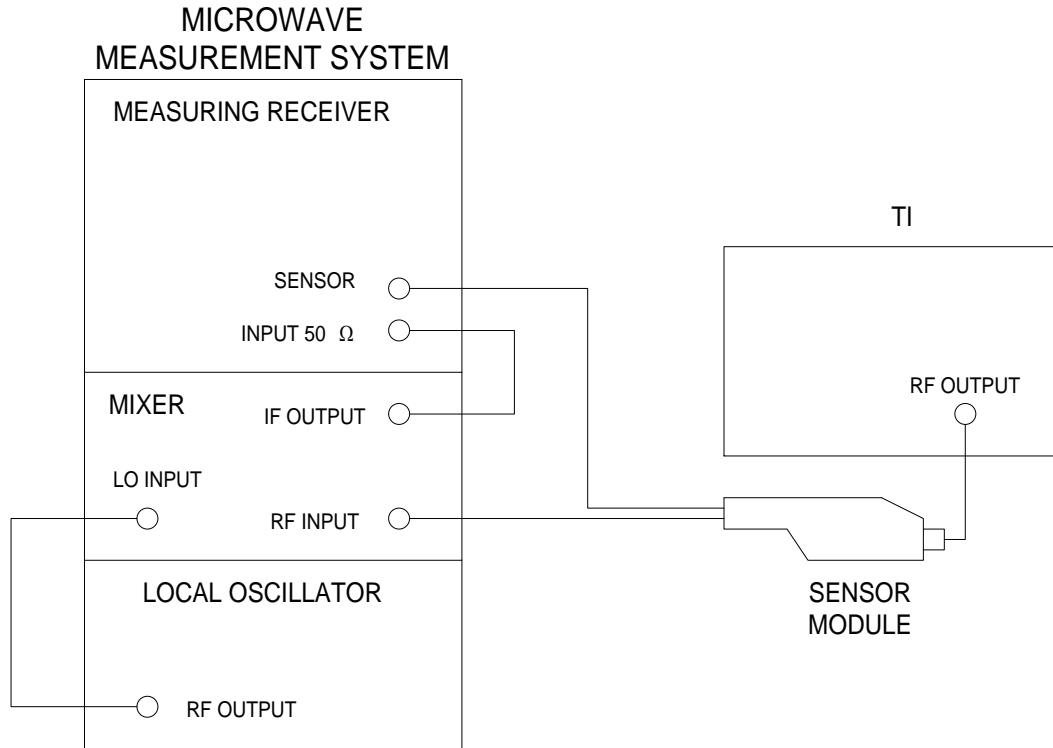

Figure 2.

4.2.10 Press the Measuring Receiver INSTR PRESET. Set the Measuring Receiver for a power measurement in the dBm mode.

4.2.11 Press TI INSTR PRESET. Press in sequence TI SHIFT, SPCL and 8 (sets TI to the HET frequency band). Press TI FREQ and set to 0.1 MHz.

4.2.12 Press TI AMPTD and set to the first value listed in the Amplitude column of Table 3.

4.2.13 Verify the Measuring Receiver indicates within the values listed in the Limits column of Table 3.

4.2.14 Repeat steps 4.2.12 and 4.2.13 for the remaining corresponding values listed in Table 3.

4.2.15 Repeat steps 4.2.12 through 4.2.14 with TI FREQ set to 10.1 and 132 MHz.

Table 3.

Band	Amplitude (dBm)	Limits (dBm)
HET	+18.0	+17.0 to +19.0
	+9.9	+8.9 to +10.9
	+5.0	+4.0 to +6.0
	0.0	-1.0 to +1.0

4.2.16 Press TI FREQ and set to 10.1 MHz. Press AMPTD and set to 0.0 dBm.

NOTE

When the Measuring Receiver RECAL light illuminates, press the CALIBRATE key and wait for a new indication.

4.2.17 Set the Measuring Receiver for a Tuned RF Level power measurement.

NOTE

Do NOT press the Measuring Receiver Blue (shift) and SET REF keys. The TI specifications are absolute levels.

4.2.18 Set TI AMPTD to the first value listed in the Amplitude column of Table 4.

4.2.19 Verify the Measuring Receiver indicates within the values listed in the Limits column of Table 4.

4.2.20 Repeat steps 4.2.18 and 4.2.19 for the remaining corresponding values listed in Table 4.

Table 4.

Band	Amplitude (dBm)	Limits (dBm)
HET	-10.0	-11.0 to -9.0
	-20.0	-21.0 to -19.0
	-30.0	-31.0 to -29.0
	-40.0	-41.0 to -39.0
	-50.0	-51.0 to -49.0
	-60.0	-61.0 to -59.0
	-70.0	-71.0 to -69.0
	-80.0	-81.0 to -79.0
	-90.0	-91.0 to -89.0
	-100.0	-101.0 to -99.0
	-110.0	-111.0 to -109.0
	-120.0	-121.0 to -119.0
-126.0	-127.0 to -125.0	

4.2.21 Press the Measuring Receiver RF POWER key. Repeat steps 4.2.16 through 4.2.20 with TI FREQ set to 132 MHz.

4.2.22 Press in sequence TI SHIFT, SPCL and 0 to disable the HET band.

4.2.23 Press the Measuring Receiver INSTR PRESET. Set the Measuring Receiver for a power measurement in the dBm mode.

4.2.24 Press TI FREQ and set to the first value listed in the Applied Frequency column of Table 5.

4.2.25 Press TI AMPTD and set to the first value listed in the Applied Amplitude column of Table 5.

4.2.26 Verify the Measuring Receiver indicates within the values listed in the Limits column of Table 5.

4.2.27 Repeat steps 4.2.25 and 4.2.26 for the remaining values listed in the Applied Amplitude column of Table 5 for the frequency being verified.

4.2.28 Repeat steps 4.2.24 through 4.2.27 for the remaining corresponding values listed in Table 5.

Table 5.

Frequency (MHz)	Applied Amplitude (dBm)	Limits (dBm)
3	+20.0	+19.0 to +21.0
	+9.9	+8.9 to +10.9
	+5.0	+4.0 to +6.0
	0.0	-1.0 to +1.0
10.1	+20.0	+19.0 to +21.0
	+9.9	+8.9 to +10.9
	+5.0	+4.0 to +6.0
	0.0	-1.0 to +1.0
100	+20.0	+19.0 to +21.0
	+9.9	+8.9 to +10.9
	+5.0	+4.0 to +6.0
	0.0	-1.0 to +1.0
500	+19.0 *	+18.0 to +20.0
	+18.0 **	+17.0 to +19.0
	+9.9	+8.9 to +10.9

See footnotes at end of Table.

Table 5. (Cont.)

Frequency (MHz)	Applied Amplitude (dBm)	Limits (dBm)
500	+5.0	+4.0 to +6.0
	0.0	-1.0 to +1.0
1000	+17.0 *	+16.0 to +18.0
	+16.0 **	+15.0 to +17.0
	+9.9	+8.9 to +10.9
	+5.0	+4.0 to +6.0
	0.0	-1.0 to +1.0
1300 *	+16.0	+15.0 to +17.0
	+9.9	+8.9 to +10.9
	+5.0	+4.0 to +6.0
	0.0	-1.0 to +1.0
2000 *	+16.0	+15.0 to +17.0
	+9.9	+8.9 to +10.9
	+5.0	+4.0 to +6.0
	0.0	-1.0 to +1.0

* For TI P/N 8642B only.

** For TI P/N 8642A only.

4.2.29 Press TI **FREQ** and set to the first value listed in the Applied Frequency column of Table 6. Ensure TI **AMPTD** is set to 0.0 dBm.

NOTE

When the Measuring Receiver **RECAL** light illuminates, press the **CALIBRATE** key and wait for a new indication.

4.2.30 Set the Measuring Receiver for a Tuned RF Level power measurement. For frequencies ≥ 1300 MHz set the measuring receiver for a Tuned RF Level power measurement in the Frequency Offset mode.

NOTE

Do NOT press the Measuring Receiver Blue (shift) and SET REF keys. The TI specifications are absolute levels.

4.2.31 Set TI AMPTD to the first value listed in the Applied Amplitude column of Table 6.

4.2.32 Verify the Measuring Receiver indicates within the values listed in the Limits column of Table 6.

4.2.33 Repeat steps 4.2.31 and 4.2.32 for the remaining corresponding values listed in Table 6 for the frequency being verified.

4.2.34 Repeat steps 4.2.29 through 4.2.33 for the remaining corresponding values listed in Table 6.

Table 6.

Frequency (MHz)	Applied Amplitude (dBm)	Limits (dBm)
3	-10.0	-11.0 to -9.0
	-20.0	-21.0 to -19.0
	-30.0	-31.0 to -29.0
	-40.0	-41.0 to -39.0
	-50.0	-51.0 to -49.0
	-60.0	-61.0 to -59.0
	-70.0	-71.0 to -69.0
	-80.0	-81.0 to -79.0
	-90.0	-91.0 to -89.0
	-100.0	-101.0 to -99.0
	-110.0	-111.0 to -109.0
-120.0	-121.0 to -119.0	
-126.0	-127.0 to -125.0	

Table 6. (Cont.)

Frequency (MHz)	Applied Amplitude (dBm)	Limits (dBm)
10.1	-10.0	-11.0 to -9.0
	-20.0	-21.0 to -19.0
	-30.0	-31.0 to -29.0
	-40.0	-41.0 to -39.0
	-50.0	-51.0 to -49.0
	-60.0	-61.0 to -59.0
	-70.0	-71.0 to -69.0
	-80.0	-81.0 to -79.0
	-90.0	-91.0 to -89.0
	-100.0	-101.0 to -99.0
	-110.0	-111.0 to -109.0
	-120.0	-121.0 to -119.0
	-126.0	-127.0 to -125.0
100	-10.0	-11.0 to -9.0
	-20.0	-21.0 to -19.0
	-30.0	-31.0 to -29.0
	-40.0	-41.0 to -39.0
	-50.0	-51.0 to -49.0
	-60.0	-61.0 to -59.0
	-70.0	-71.0 to -69.0
	-80.0	-81.0 to -79.0
	-90.0	-91.0 to -89.0
	-100.0	-101.0 to -99.0

Table 6. (Cont.)

Frequency (MHz)	Applied Amplitude (dBm)	Limits (dBm)
100	-110.0	-111.0 to -109.0
	-120.0	-121.0 to -119.0
	-126.0	-127.0 to -125.0
500	-10.0	-11.0 to -9.0
	-20.0	-21.0 to -19.0
	-30.0	-31.0 to -29.0
	-40.0	-41.0 to -39.0
	-50.0	-51.0 to -49.0
	-60.0	-61.0 to -59.0
	-70.0	-71.0 to -69.0
	-80.0	-81.0 to -79.0
	-90.0	-91.0 to -89.0
	-100.0	-101.0 to -99.0
1000	-110.0	-111.0 to -109.0
	-120.0	-121.0 to -119.0
	-126.0	-127.0 to -125.0
	-10.0	-11.0 to -9.0
	-20.0	-21.0 to -19.0
	-30.0	-31.0 to -29.0
	-40.0	-41.0 to -39.0
-50.0	-51.0 to -49.0	
-60.0	-61.0 to -59.0	
-70.0	-71.0 to -69.0	

Table 6. (Cont.)

Frequency (MHz)	Applied Amplitude (dBm)	Limits (dBm)
1000	-80.0	-81.0 to -79.0
	-90.0	-91.0 to -89.0
	-100.0	-101.0 to -99.0
	-110.0	-111.0 to -109.0
	-120.0	-121.0 to -119.0
	-126.0	-127.0 to -125.0
1300 *	-10.0	-11.0 to -9.0
	-20.0	-21.0 to -19.0
	-30.0	-31.0 to -29.0
	-40.0	-41.0 to -39.0
	-50.0	-51.0 to -49.0
	-60.0	-61.0 to -59.0
	-70.0	-71.0 to -69.0
	-80.0	-81.0 to -79.0
	-90.0	-91.0 to -89.0
	-100.0	-101.0 to -99.0
	-110.0	-111.0 to -109.0
	-120.0	-121.0 to -119.0
-126.0	-127.0 to -125.0	
2000 *	-10.0	-11.0 to -9.0
	-20.0	-21.0 to -19.0
	-30.0	-31.0 to -29.0
	-40.0	-41.0 to -39.0

See footnote at end of Table.

Table 6. (Cont.)

Frequency (MHz)	Applied	Amplitude (dBm)	Limits (dBm)
2000 *		-50.0	-51.0 to -49.0
		-60.0	-61.0 to -59.0
		-70.0	-71.0 to -69.0
		-80.0	-81.0 to -79.0
		-90.0	-91.0 to -89.0
		-100.0	-101.0 to -99.0
		-110.0	-111.0 to -109.0

* For TI P/N 8642B only.

NOTE

Calibrate the TI RF Output to the dynamic range of the Microwave Measurement System.

4.2.35 Set TI RF OFF/ON to OFF.

4.2.36 Set LO (p/o Microwave Measurement System) Output to minimum and disconnect the test setup.

4.3 HARMONICS AND SUBHARMONICS CALIBRATION:

4.3.1 Connect TI RF OUTPUT to Spectrum Analyzer INPUT 50 Ω .

4.3.2 Set TI AMPTD and FREQ to the first values listed in the Applied columns of Table 7 and set TI RF OFF/ON to ON.

4.3.3 Set the Spectrum Analyzer to view the Harmonics and Subharmonics.

4.3.4 Verify the Harmonic and Subharmonic levels are within the values listed in the Limits columns of Table 7.

4.3.5 Repeat steps 4.3.2 through 4.3.4 for the remaining values listed in the Applied columns of Table 7.

Table 7.

AMPTD (dBm)	Applied FREQ (MHz)	Limits (dBc)	
		Harmonic	Subharmonic
+16	1.000000	≤-20	None *
	1.500000	≤-20	None *
	166.666667	≤-20	None *
	250.000000	≤-20	None *
	500.000000	≤-20	None *
	333.333333	≤-20	None *
	2000.000000 **	≤-20	≤-45
+10	1.000000	≤-30	None *
	1.500000	≤-30	None *
	166.666667	≤-30	None *
	250.000000	≤-30	None *
	500.000000	≤-30	None *
	333.333333	≤-30	None *
	2000.000000 **	≤-25	≤-45

* By design, Subharmonics are not produced and therefore not checked.

** For TI P/N 8642B only.

4.3.7 Set TI RF OFF/ON to OFF and disconnect the test setup.

4.4 NON-HARMONICS, SINGLE-SIDEBAND PHASE NOISE AND RESIDUAL FM CALIBRATION:

CAUTION

Do not connect outputs of Phase Noise Measurement System Reference Source or TI to the Inputs of the Phase Noise Measurement System until instructed to do so. Damage to the Phase Noise Measurement System can result if Reference Source or TI output power is applied to the system before the internal attenuators are set. If not strictly observed, could result in damage to, or destruction of, equipment or loss of mission effectiveness.

4.4.1 Press TI INSTR PRESET, set FREQ to 4 MHz, AMPTD to +10.0 dBm.

4.4.2 Verify the Phase Noise Measurement System is using the current Software Package CPIN number 88M-E5504B/NOISE-F001-01A, with the latest revision, as per ACPINS. The Desktop should be present on the screen when the computer is turned on.

4.4.3 Access the Phase Noise Calibration Program.

4.4.4 Select Define, then select Measurement.

4.4.5 On Phase Noise Measurement System select Preset. Select Yes. Set Offset Frequency Range Start Offset to 10 Hz and Stop Offset to 1E+6 Hz.

4.4.6 On Phase Noise Measurement System select Sources. Select Preset. Select Yes. Set the following:

Carrier Source

Frequency 4E+6 Hz

Power 10 dBm

Reference Source

Power 16 dBm

VCO Tuning Parameters

Nominal Tune Constant 10E+3

Tune Range +/- 5 Volts

Input Resistance 600 Ohms

4.4.7 On Phase Noise Measurement System select Cal. Select Preset. Select Yes. Select Calculated from expected VCO tune constant using tune port resistance. De-select Verify calculated phase locked loop suppression.

4.4.8 On Phase Noise Measurement System select Block Diagram. Select Preset. Select Yes. Select Downconverter None. Select VCO Tune Mode DC FM and Reference Source Agilent/HP 8664A.

4.4.9 On Phase Noise Measurement System select Test Set. Select Preset. Select Yes. Set LNA Low Pass Filter to 200 kHz and de-select Auto.

4.4.10 On Phase Noise Measurement System select Graph. Select Preset. Select Yes. Enter graph title as appropriate. Set X Scale Minimum to 10E+3 and Maximum to 30E+3. Select Close.

4.4.11 On Phase Noise Measurement System select Measure. Select New Measurement. Select Yes when prompted to perform a new calibration and measurement.

CAUTION

PC Digitizer (P/O Phase Noise Measurement System) INPUT and OUTPUT connectors are fragile. Damage can occur to the PC Digitizer INPUT and OUTPUT connectors and cables while connected if tension is applied. If not strictly observed, could result in damage to, or destruction of, equipment or loss of mission effectiveness.

4.4.12 Connect equipment as shown in Figure 3 and set TI RF OFF/ON to ON. Connect dashed line for frequencies >1600 MHz.

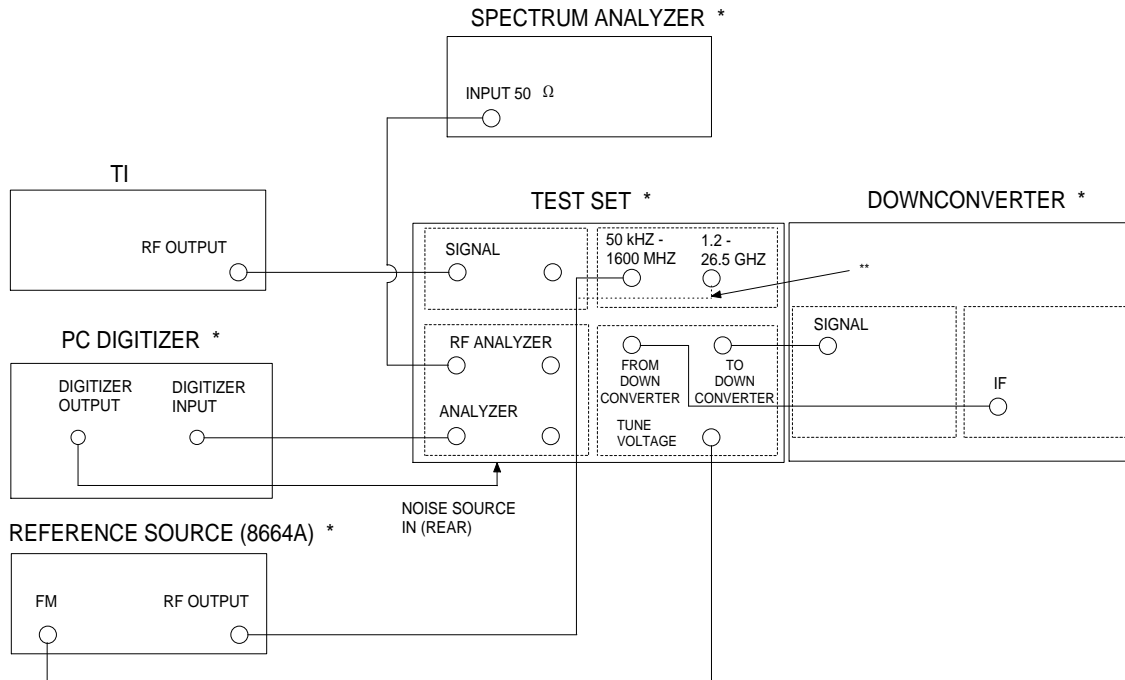

* P/O Phase Noise Measurement System.

** Connect dashed line for frequencies >1600 MHz.

Figure 3.

4.4.13 When Verify Connections diagram appears on screen, ignore on-screen diagram and select Continue.

4.4.14 The Phase Noise Plot must be within the specifications in Table 1 for the frequency being verified. Verify the Non-Harmonic spurious signals for offset frequencies >10 kHz are within the specifications in Table 1 for the frequency being verified. If desired, the Marker icon may be used to obtain specific offset frequencies and corresponding phase noise measurements on the graph.

4.4.15 On Phase Noise Measurement System select Analyze, then select Trace Integration.

4.4.16 From the Trace Integration screen, set the Data Type to Snu(f) (Spectral density of frequency fluctuations). Set the Data to Integrate to Noise. Set the Start Offset to 300 Hz and Stop Offset to 3E+3. Select Integrate.

- 4.4.17 Verify the Value of Definite Integral is within the specifications in Table 1 for Residual FM (300 Hz to 3 kHz Bandwidth).
- 4.4.18 From the Trace Integration screen, set the Start Offset to 50 Hz and Stop Offset to 15E+3. Select Integrate.
- 4.4.19 Verify the Value of Definite Integral is within the specifications in Table 1 for Residual FM (50 Hz to 15 kHz Bandwidth). Select Close.
- 4.4.20 On Phase Noise Measurement System select Define, then select Measurement.
- 4.4.21 On Phase Noise Measurement System select Sources to change Carrier Source Frequency to 8E+6. Select Close.
- 4.4.22 Press TI FREQ and set to 8 MHz.
- 4.4.23 Repeat steps 4.4.11 through 4.4.20 for 8 MHz.
- 4.4.24 On Phase Noise Measurement System select Sources to change Carrier Source Frequency to 16E+6. Select Close.
- 4.4.25 Press TI FREQ key and set to 16 MHz.
- 4.4.26 Repeat steps 4.4.11 through 4.4.20 for 16 MHz.
- 4.4.27 On Phase Noise Measurement System select Sources to change Carrier Source Frequency to 33E+6. Select Close.
- 4.4.28 Press TI FREQ key and set to 33 MHz.
- 4.4.29 Repeat steps 4.4.11 through 4.4.20 for 33 MHz.
- 4.4.30 On Phase Noise Measurement System select Sources to change Carrier Source Frequency to 66E+6. Select Close.
- 4.4.31 Press the TI FREQ key and set to 66 MHz.
- 4.4.32 Repeat steps 4.4.11 through 4.4.20 for 66 MHz.
- 4.4.33 On Phase Noise Measurement System select Sources to change Carrier Source Frequency to 132E+6. Select Close.
- 4.4.34 Press the TI FREQ key and set to 132 MHz.
- 4.4.35 Repeat steps 4.4.11 through 4.4.20 for 132 MHz.
- 4.4.36 On Phase Noise Measurement System select Sources to change Carrier Source Frequency to 264E+6. Select Close.
- 4.4.37 Press TI FREQ key and set to 264 MHz.
- 4.4.38 Repeat steps 4.4.11 through 4.4.20 for 264 MHz.

4.4.39 On Phase Noise Measurement System select Sources to change Carrier Source Frequency to 528E+6. Select Close.

4.4.40 Press TI FREQ key and set to 528 MHz.

4.4.41 Repeat steps 4.4.11 through 4.4.20 for 528 MHz.

4.4.42 On Phase Noise Measurement System select Sources to change Carrier Source Frequency to 1057E+6. Select Close.

4.4.43 Press TI FREQ key and set to 1057 MHz.

4.4.44 Repeat steps 4.4.11 through 4.4.20 for 1057 MHz.

4.4.45 For TI model 8642A, proceed to step 4.4.49. For TI model 8642B, continue with step 4.4.46.

4.4.46 On Phase Noise Measurement System select Sources to change Carrier Source Frequency to 2110E+6 and Power to 5 dBm. Set Reference Source Power to 8 dBm. Select Close.

4.4.47 Press TI FREQ key and set to 2110 MHz. Press AMPTD and set to +5 dBm.

4.4.48 Repeat steps 4.4.11 through 4.4.20 for 2110 MHz.

4.4.49 Press in turn TI SHIFT, SPLC and 8 (sets TI to the HET frequency band). Press FREQ key and set to 60 MHz. Press AMPTD and set to +10 dBm.

4.4.50 On Phase Noise Measurement System select Sources to change Carrier Source Frequency to 60E+6 and Power to 10 dBm. Set Reference Source Power to 16 dBm. Select Close.

4.4.51 Repeat steps 4.4.11 through 4.4.19 for 60 MHz.

4.4.52 Press in turn TI SHIFT, SPLC, 2, 0 and 8 (returns TI to operating on Frequency Bands 1 through 10).

4.4.53 Set TI RF OFF/ON to OFF. Set all outputs to minimum and leave the test setup connected. ■

4.5 INCIDENTAL AM CALIBRATION:

4.5.1 Press TI INSTR PRESET, AMPTD and set to +9.0 dBm.

4.5.2 Access the Phase Noise Calibration Program.

4.5.3 Select Define, then select Measurement.

4.5.4 On the Phase Noise Measurement System set Measurement Type to AM Noise. Set Offset Frequency Range Start Offset to 10 Hz and Stop Offset to 100 E+3.

4.5.5 On the Phase Noise Measurement System select Source. Select Preset. Select Yes. Set the following:

Carrier Source

Frequency	100E+06 Hz
Power	9 dBm
Detector Input Frequency	100E+06 Hz

4.5.6 On the Phase Noise Measurement System select Cal. Select Preset. Select Yes. Select Detector Constant Derive detector constant from double-sided spur. Set the following:

Known Spur Parameters

Offset Frequency	1E+3 Hz
Amplitude	-46 dBc

NOTE

$$dBc = 20 \log \left(\frac{Modulation}{2} \right)$$

The modulation value is entered as a decimal value not as the percentage.

Therefore, -46.0 dBc corresponds to 1.0% (0.01) AM Modulation

4.5.7 On the Phase Noise Measurement System select Block Diagram. Select Preset. Select Yes. Set AM Detector to Test Set AM Detector.

4.5.8 On the Phase Noise Measurement System select Graph. Select Preset. Select Yes. Enter graph title as appropriate for your set-up. Set X Scale Minimum to 10 Hz and X Scale Maximum to 100E+3. Set Y Scale Maximum to -20 dBc/Hz. Select Close.

- 4.5.9 Press TI FREQ and enter the first value listed in the Applied column of Table 9. On the Phase Noise Measurement System select Measure. Select New Measurement. Select Yes when prompted to perform a new calibration and measurement. When verify connections diagram appears, select Continue.
- 4.5.10 Wait for the Phase Noise Measurement System to display Apply modulation to carrier signal. Press TI AM and INT and set AM Depth to 1%.
- 4.5.11 On the Phase Noise Measurement System, select Continue.
- 4.5.12 When prompted to remove modulation from carrier signal, set TI OFF/ON to OFF.
- 4.5.13 Press TI FM, INT and set TI FM to 20.0 kHz. Press MOD FREQ and set to 1 kHz.
- 4.5.14 On the Phase Noise Measurement System, select Continue.
- 4.5.15 Wait until the Phase Noise Measurement System completes the calibration.

NOTE

The Phase Noise Measurement System AM Noise Measurement is accurate to ± 3 dB. Since the TI specification is for 0.3% AM (-56.5 dBc) and the accuracy of the Phase Noise Measurement System of ± 3 dB must be taken into consideration, the -59.5 dBc level must be used as the limit.

4.5.16 The amplitude of the 1 kHz spur must indicate < -59.5 dBc/Hz. If desired, the Marker icon may be used to obtain specific offset frequencies and corresponding Incidental AM measurements and spurious signals on the graph.

4.5.17 Select Define, then select Measurement.

4.5.18 On the Phase Noise Measurement System select Source. Set the Carrier Source Frequency and Detector Input Frequency to the next value listed in the Applied column of Table 9. Select Close.

4.5.19 Press TI FM and set OFF/ON to OFF.

4.5.20 Repeat steps 4.5.9 through 4.5.19 for the remaining values listed in Table 9.

Table 9.

Applied (MHz)	Limits (dBc/Hz)
100.0	< -59.5
950.0	< -59.5
1700.0 *	< -59.5
2000.0 *	< -59.5

* For TI P/N 8642B only.

4.5.21 Set all outputs to minimum and disconnect the test setup.

4.6 AMPLITUDE MODULATION CALIBRATION:

4.6.1 Press TI INSTR PRESET.

4.6.2 Connect equipment as shown in Figure 4.

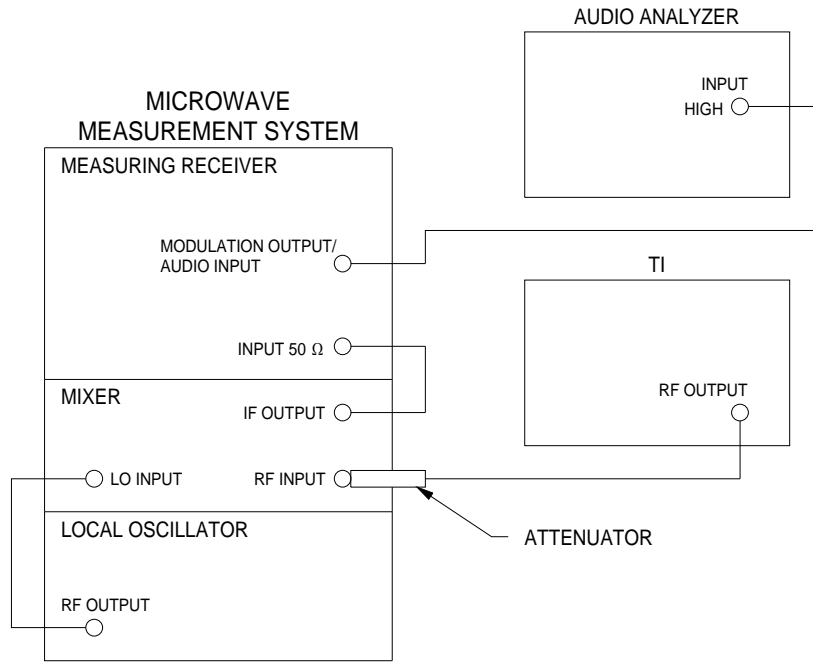

Figure 4.

- 4.6.2 Press TI AMPTD key and set to +10 dBm. Set TI RF OFF/ON to ON.
- 4.6.3 Press TI FREQ key and enter the first value listed in the Frequency column of Table 10.
- 4.6.4 Press TI AM key and enter the first value listed in the Depth column of Table 10.
- 4.6.5 Press TI MOD/FREQ, and set to 1 kHz.
- 4.6.6 Press the Measuring Receiver INSTR PRESET and set the Measuring Receiver for an amplitude modulation measurement.
- 4.6.7 Select the Measuring Receiver PEAK ± 2 DETECTOR, 300 Hz HP FILTER and 15 kHz LP FILTER.
- 4.6.8 Verify the Measuring Receiver indicates within the values listed in the Limits Depth column of Table 10.
- 4.6.9 Set the Audio Analyzer MEASUREMENT to DISTN and select the 30 kHz LP FILTER.
- 4.6.10 Verify the Audio Analyzer indicates within the value listed in the Limits Distortion column of Table 10 for the appropriate TI Model being calibrated.
- 4.6.11 Repeat steps 4.6.3, 4.6.4, 4.6.8 and 4.6.10 for the remaining corresponding values listed in Table 10.

Table 10.

Frequency (MHz)	Depth (%)	Limits	
		Depth (%)	Distortion (%)
1	30	27.9 to 32.1	<1
	50	47.2 to 52.8	<2
	90	85.8 to 94.2	<4
100	30	27.9 to 32.1	<1
	50	47.2 to 52.8	<2
	90	85.8 to 94.2	<4
500	30	27.9 to 32.1	<1
	50	47.2 to 52.8	<2
	90	85.8 to 94.2	<4
1000 * ¹	30	27.5 to 32.5	<2
	50	46.5 to 53.5	<4
	90	84.5 to 95.5	<6
1000 * ²	30	27.9 to 32.1	<1
	50	47.2 to 52.8	<2
	90	85.8 to 94.2	<4
1500 * ² , * ³	30	27.5 to 32.5	<2
	50	46.5 to 53.5	<4
	90	84.5 to 95.5	<6
2000 * ² , * ³	30	27.5 to 32.5	<2
	50	46.5 to 53.5	<4
	90	84.5 to 95.5	<6

*¹ For TI P/N 8642A only.

*² For TI P/N 8642B only.

*³ Set the Microwave Measurement System for a Measurement in the Frequency Offset Mode.

4.6.11 Press TI INSTR PRESET. Set TI FREQ to 1050 MHz, AMPTD to +10 dBm, and AM to 30%.

4.6.12 Press the Measuring Receiver INSTR PRESET and set the Measuring Receiver for a phase modulation measurement. Select the Measuring Receiver 300 Hz HP FILTER and the 15 kHz LP FILTER.

4.6.13 Verify the Measuring Receiver indicates <0.20 rads peak.

4.6.14 Set TI RF OFF/ON to OFF and leave test setup connected.

4.7 PHASE MODULATION CALIBRATION:

4.7.1 Press TI INSTR PRESET.

4.7.2 Press TI AMPTD key and set to +10 dBm.

4.7.3 Press the Measuring Receiver INSTR PRESET and set the Measuring Receiver for a phase modulation measurement. Select the Measuring Receiver 300 Hz HP FILTER and the 15 kHz LP FILTER.

4.7.4 Set the TI FREQ and ϕ M deviation to the first values listed in Table 11 and set TI RF OFF/ON to ON.

4.7.5 Verify the Measuring Receiver indicates within the values listed in the Limits Deviation column of Table 11.

4.7.6 Set the Audio Analyzer MEASUREMENT to DISTN and select the 30 kHz LP FILTER.

4.7.7 Verify the Audio Analyzer indicates within the value listed in the Limits Distortion column of Table 11.

Table 11.

FREQ (MHz)	ϕ M (RAD)	Limits	
		Deviation (ϕ M)	Distortion (%)
8.00	0.781	0.652 to 0.910	<0.4
1050	100.0	94.9 to 105.1	<0.4
0.15	6.25	5.847 to 6.653	<0.4

4.7.8 Repeat steps 4.7.4, 4.7.5 and 4.7.7 for the remaining corresponding values listed in Table 11.

4.7.9 Set TI RF OFF/ON to OFF and leave test setup connected.

4.8 FREQUENCY MODULATION CALIBRATION:

4.8.1 Press TI INSTR PRESET.

4.8.2 Press TI AMPTD key and set to +10 dBm. Set TI RF OFF/ON to ON.

4.8.3 Press TI FREQ key and enter the first value listed in the Frequency column of Table 12. Press TI FM key and enter the first value listed in the Applied Deviation column of Table 12. Press TI MOD FREQ key and enter the first value listed in the Applied Rate column of Table 12.

4.8.4 Press the Measuring Receiver INSTR PRESET, then FM keys. Press PEAK+ and select the 300 Hz HP FILTER and LP FILTER as necessary.

4.8.5 Verify the Measuring Receiver indicates within the values listed in the Limits Deviation column of Table 12.

4.8.6 Set the Audio Analyzer MEASUREMENT to DISTN and select the proper LP FILTER as necessary for the Applied Rate being measured.

4.8.7 Verify the Audio Analyzer indicates within the value listed in the Limits Distortion column of Table 12.

4.8.8 Repeat steps 4.8.3 through 4.8.7 for the remaining corresponding values listed in Table 12.

Table 12.

Frequency (MHz)	Applied		Limits	
	Deviation (kHz)	Rate (kHz)	Deviation (kHz)	Distortion (%)
2	90	10	85.5 to 94.5	<4
8	10	10	9.5 to 10.5	<4
16	20	20	19.0 to 21.0	<4
		50	19.0 to 21.0	<4
		100	19.0 to 21.0	<4
32	40	20	38.0 to 42.0	<4
		50	38.0 to 42.0	<4
		100	38.0 to 42.0	<4
64	90	20	85.5 to 94.5	<4
		50	85.5 to 94.5	<4
		100	85.5 to 94.5	<4
132	180	20	171 to 189	<4
		50	171 to 189	<4
		100	171 to 189	<4
264	25	100	23.74 to 26.26	<0.4
	188	100	178.6 to 197.4	<2
	375	100	356.2 to 393.8	<4

Table 12. (Cont.)

Frequency (MHz)	Applied		Limits	
	Deviation (kHz)	Rate (kHz)	Deviation (kHz)	Distortion (%)
375 *	350	20	332.5 to 367.5	<2
		50	332.5 to 367.5	<2
		100	332.5 to 367.5	<2
1000	100	20	95.0 to 105.0	<0.4
		50	95.0 to 105.0	<0.4
		100	95.0 to 105.0	<0.4
2000 **	200	20	190.0 to 210.0	<0.4
		50	190.0 to 210.0	<0.4
		100	190.0 to 210.0	<0.4

* Record Measuring Receiver indication for later use.

** For TI P/N 8642B only.

4.8.9 Set TI RF OFF/ON to OFF and disconnect test setup.

4.8.10 Connect equipment as shown in Figure 5.

4.8.11 Press TI INSTR PRESET, then set TI FREQ to 400 MHz and AMPTD to +13 dBm

4.8.12 Using the automation package of the Phase Noise Measurement System, access the Phase Noise Calibration Program.

NOTE

If unable to select Meter, it may be necessary to measure the Phase Noise of a 400 MHz signal using method in para 4.4. When prompt for zero beat is displayed, Meter may then be selected.

4.8.13 On the Phase Noise Measurement System, select View, then Meter.

4.8.14 Tune TI FREQ until the on screen Meter indicates about 0.

4.8.15 Press PRESET on the Spectrum Analyzer. Set the Spectrum Analyzer to span 0 to 100 kHz.

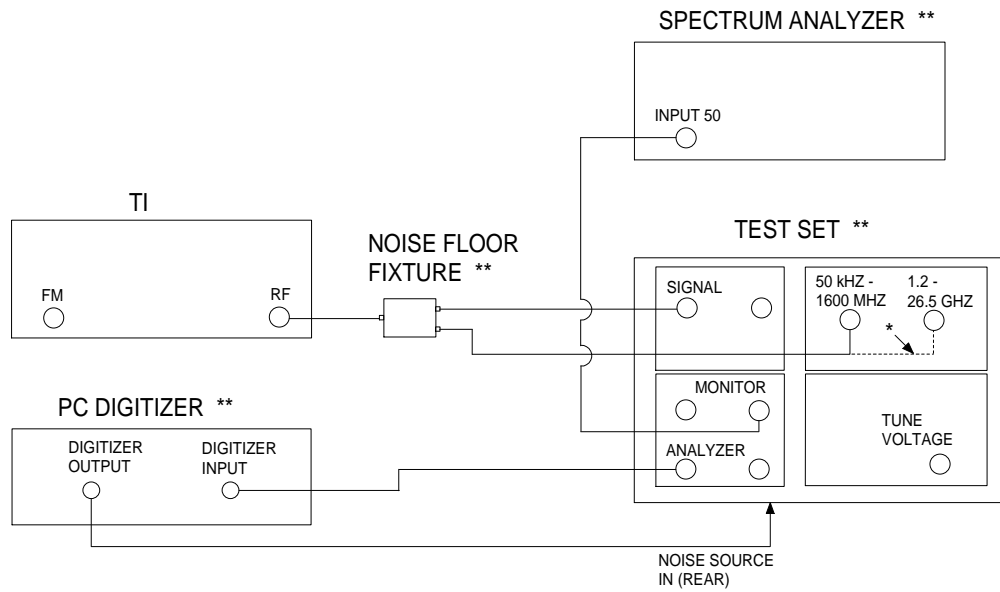

* Connect dashed line for carrier frequencies >1600 MHz.

** P/O Phase Noise Measurement System.

Figure 5.

4.8.16 Calculate indicator accuracy by the following formula:

$$IA = 700 - D$$

Where:

IA = Indicator Accuracy

D = value recorded in Table 12

4.8.17 Press TI FM, then key in the value calculated in step 4.8.16, then press kHz. Key in MOD FREQ 20 kHz.

4.8.18 Press Spectrum Analyzer Peak Search, Markers and select Delta.

4.8.19 Set TI FM to 750 kHz. Press Spectrum Analyzer Peak Search. The Spectrum Analyzer must indicate between 6.2 and 7.0 dB.

4.8.20 Set the Spectrum Analyzer to measure harmonics of the fundamental signal. The harmonics must be >27.96 dB down from the fundamental signal.

4.8.21 Set TI RF OFF/ON to OFF and disconnect test setup.

4.9 PULSE MODULATION CALIBRATION:

4.9.1 PULSE ON/OFF RATIO CALIBRATION:

4.9.1.1 Press TI INSTR PRESET.

4.9.1.2 Press PRESET on the Spectrum Analyzer.

4.9.1.3 Connect TI RF OUTPUT through the Attenuator to the Spectrum Analyzer INPUT 50 Ω.

4.9.1.4 Set TI FREQ to to the first value listed in the Frequency column of Table 13 and AMPD to +10 dBm.

4.9.1.5 Set the Spectrum Analyzer controls to view the fundamental. Set the controls to place the fundamental at the top graticule line. Set the controls as required for at least 80 dB of sensitivity.

4.9.1.6 Press TI SHIFT, PULSE and OFF/ON to ON.

4.9.1.7 Verify the signal on the Spectrum Analyzer is within the values listed in the Limits column of Table 13 for the TI being calibrated.

Table 13.

Frequency (MHz)	Limits (dBc)	
	S/N 2509A to 2550A	S/N ≥2551A
1000.0	<-30	<-40
1300.0 *	<-45	<-80

* For TI P/N 8642B only.

4.9.1.8 If applicable, repeat steps 4.9.1.4 through 4.9.1.7 for the remaining frequency values listed in Table 13.

4.9.1.9 Set the TI OFF/ON and RF OFF/ON to OFF. Disconnect the test setup.

4.9.2 RISE/FALL TIME CALIBRATION:

4.9.2.1 Press TI INSTR PRESET.

4.9.2.2 Connect equipment as shown in Figure 6.

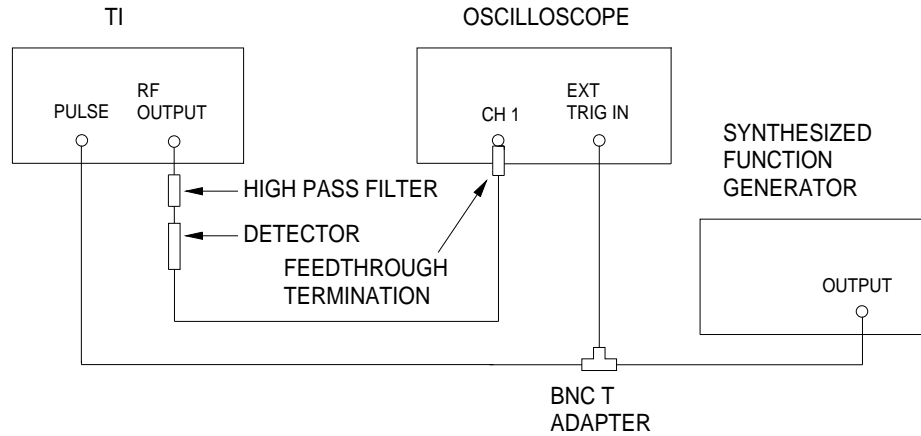

Figure 6.

4.9.2.3 Set TI FREQ to 1000 MHz, AMPTD to +13 dBm, SHIFT, PULSE and OFF/ON to ON.

4.9.2.4 Set the Synthesized Function Generator as follows:

Function	Pulse
Frequency	50 kHz (S/N 2509A to 2550A) 100 kHz (S/N \geq 2551A)
Amplitude	1 V pk
Amplitude Offset	1 V
Pulse Width	6 μ s (S/N 2509A to 2550A) 2 μ s (S/N \geq 2551A)

4.9.2.5 Set the Oscilloscope controls to view the displayed pulse.

4.9.2.6 Adjust Synthesized Function Generator for 6 μ s (S/N 2509A to 2550A) or 2 μ s (S/N \geq 2551A) as displayed on the Oscilloscope.

4.9.2.7 On the Oscilloscope, verify the Modulation Pulse Rise/Fall Time is <3.5 μ s (S/N 2509A to 2550A) or <400 ns (S/N \geq 2551A) between 10 and 90%.

4.9.2.8 Set TI RF OFF/ON to OFF. Disconnect the test setup.

4.10 **RESIDUAL AM CALIBRATION:**

4.10.1 Press TI INSTR PRESET. Connect TI RF OUTPUT to the Measuring Receiver INPUT 50 Ω .

4.10.2 Press the Measuring Receiver INSTR PRESET. Set the Measuring Receiver for an amplitude modulation measurement. Select RMS mode and the 300 Hz HP FILTER and 3 kHz LP FILTER.

4.10.3 Set TI AMPTD and FREQ to the first values listed in the Applied columns of Table 14.

4.10.4 Verify the Measuring Receiver indicates within the value listed in the Limits column of Table 14.

Table 14.

AMPTD (dBm)	Applied	FREQ (MHz)	Limits (% AM rms)
18		1.0	<0.010
18		1000	<0.010
16		1300 *	<0.010
5		1.0	<0.010
5		1000	<0.010
5		1300 *	<0.010

* For TI P/N 8642B only.

4.10.5 Repeat steps 4.10.3 and 4.10.4 for the remaining corresponding values listed in the Applied columns of Table 14.

4.10.6 Set TI RF OFF/ON to OFF. Disconnect the test setup.

4.11 INTERNAL MODULATION OSCILLATOR CALIBRATION:

4.11.1 Press TI INSTR PRESET.

4.11.2 Connect TI MOD OUTPUT to Audio Analyzer HIGH INPUT. Set the Audio Analyzer MEASUREMENT to AC LEVEL. Set ground to FLOAT.

4.11.3 Set TI MOD FREQ and MOD OUT to the first values listed in the Applied columns of Table 15.

4.11.4 Verify the Audio Analyzer indicates within the values listed in the Limits column of Table 15.

Table 15.

MOD FREQ (kHz)	Applied	MOD OUT (V)	Limits (V)
0.020 *		50 m	46.6 m to 94.8 m
1.000 *		50 m	46.6 m to 94.8 m
100.0 **		50 m	46.6 m to 94.8 m
0.020 *		3.00	4.051 to 4.433
1.00 *		3.00	4.051 to 4.433
100.0 **		3.00	4.051 to 4.433

* Select Audio Analyzer 30 kHz LP FILTER.

** Remove low pass filters.

4.11.5 Repeat steps 4.11.3 and 4.11.4 for the remaining corresponding values listed in the Applied columns of Table 15.

4.11.6 Set TI MOD FREQ to the first value listed in Table 16.

4.11.7 Verify the frequency indicated on the Audio Analyzer is within the values listed in the Limits column of Table 16.

Table 16.

MOD FREQ (Hz)	Limits (Hz)
20.0	19.6 to 20.4
14.9 k	14.6 k to 15.2 k
15.1 k	14.8 k to 15.4 k
100.0 k	98.0 k to 102.0 k

4.11.8 Repeat steps 4.11.6 and 4.11.7 for the remaining values listed in the MOD FREQ column of Table 16.

4.11.9 Set the Audio Analyzer MEASUREMENT to DISTN and set the LOG LIN to LIN.

4.11.10 Set TI MOD FREQ and MOD OUT to the first values listed in the Applied columns of Table 17.

4.11.11 Verify the distortion indicated on the Audio Analyzer is within the values listed in the Limits column of Table 17.

Table 17.

MOD FREQ (kHz)	Applied	MOD OUT (V)	Limits (%)
0.020 *		0.50	<0.02
15.80 **		0.50	<0.02
100.0 **		0.50	<0.15
0.020 *		3.00	<0.02
15.80 **		3.00	<0.02
100.0 **		3.00	<0.15

* Select Audio Analyzer 30 kHz LP FILTER.

** Remove low pass filters.

4.11.12 Repeat steps 4.11.10 and 4.11.11 for the remaining corresponding values listed in the Applied columns of Table 17.

4.11.13 Set the TI RF OFF/ON to OFF.

T.O. 33K4-4-260-1

4.11.14 Set all POWER switches to OFF/STANDBY, disconnect and secure all equipment.

4.11.15 Attached a Limited Certification Label as per step 3.4.1.

CALIBRATION PERFORMANCE TABLE

Not Required

APPENDIX A**NOTE**

Appendix do not apply to the STD TI. STD TI Oscillator is not adjustable.

A-1 TIME BASE ADJUSTMENT: [Room Temperature Crystal Oscillator (RTXO)]

A.1.1 Connect Frequency Standard 10 MHz REF OUT to Electronic Counter EXT FREQ STD INPUT (1-10 MHz). Set Electronic Counter INT STD/EXT STD switch to EXT STD.

A-1.2 Connect TI 10 MHz OUT to Electronic Counter CHANNEL A input. Set Electronic Counter 50Ω/1MΩ switch to 50Ω.

A-1.3 Adjust the TI OSC ADJ for an Electronic Counter indication as close as possible to 10 MHz.

A-1.4 Allow TI 10 MHz Oscillator a minimum of one (1) hour to stabilize. Repeat step A-1.3 as required.

A-1.5 Disconnect the test setup and continue with para 4.2.

A-2 TIME BASE ADJUSTMENT: [Temperature Compensated Crystal Oscillator (TCXO)]

A-2.1 Connect Frequency Standard 10 MHz REF OUT to Electronic Counter EXT FREQ STD INPUT (1-10 MHz). Set Electronic Counter INT STD/EXT STD switch to EXT STD.

A-2.2 Connect TI 10 MHz OUT to Electronic Counter CHANNEL A input. Set Electronic Counter 50Ω/1MΩ switch to 50Ω and GATE TIME to 1 sec.

A-2.3 Adjust the TI OSC ADJ for an Electronic Counter indication as close as possible to 10 MHz ± the Offset labeled on the cover of the TCXO. For example: If the Offset is labeled +3.5 Hz, the TCXO should be adjusted as close as possible to a frequency indication of 10.000 003 5 MHz on the Electronic Counter.

A-2.3 Allow TI 10 MHz Oscillator a minimum of one (1) hour to stabilize. Repeat step A-2.3 as required.

A-2.4 Disconnect the test setup and continue with para 4.2.

A-3 TIME BASE ADJUSTMENT: [Oven Controlled Crystal Oscillator (OCXO)]

A-3.1 Connect Frequency Standard 10 MHz FREQ OUT to Frequency Difference Meter (FDM) REF INPUT. Connect TI rear panel 10 MHz OUT to the FDM SIG INPUT connector.

A-3.2 Standardize the FDM as required. Set FDM METER RANGE switch as required for an on scale indication on the FDM.

A-3.3 Adjust TI OSC ADJ, as required for lowest possible null on the FDM meter.

A-3.4 Allow TI 10 MHz Oscillator a minimum of one (1) hour to stabilize and repeat step A-3.3 as required.

A-3.5 Disconnect equipment from TI and continue with para 4.2.

APPENDIX B

Table B-1.
TI Single Sideband Phase Noise Limitations Using Phase Noise Measurement System

TI (MHz)	TI Spec (dBc/Hz) @ 20 kHz offset	TI Limitations (dBc/Hz)
Band 10 (1057.500001 to 2115)	-125	None (1057.500001 to 2060 MHz) * -122 (>2060 to 2115 MHz)
Band 9 (528.750001 to 1057.5)	-134	None (528.750001 to 1030 MHz) * -128 (>1030 to 1057.5 MHz)
Band 8 (264.375001 to 528.75)	-137	None (264.375001 to 515 MHz) * -134 (>515 to 528.75 MHz)
Band 7 (132.187501 to 264.375)	-141	-131 (132.187501 to 187.5 MHz) None (>187.5 to 257.5 MHz) * -140 (>257.5 to 264.375 MHz)
Band 6 (66.093751 to 132.1875)	-144	-131
Band 5 (33.046876 to 66.09375)	-145	-131
Band 4 (16.523438 to 33.046875)	-146	-131
Band 3 (8.261719 to 16.523437)	-147	-131
Band 2 (4.13086 to 8.261718)	-148	-131
Band 1 (0.1 to 4.130859)	-137	-131
HET (0.1 to 132.1875)	-125	None *

* No limitation required.